

Simple Machines

- Machines make _____ easier
- Energy is _____ so same _____ of energy _____ or _____ machine

Mechanical Advantage (MA)

• $MA = \frac{F_o}{F_i}$

Lever

- Uses _____ with _____ at N
- $F_i l_i = F_o l_o$
- $\frac{F_o}{F_i} = \frac{l_i}{l_o}$
- When $F \uparrow, l \downarrow$
- $MA = \frac{F_o}{F_i} = \frac{l_i}{l_o}$

Wheel and Axle

- _____

Inclined Plane

- _____ - less _____ to slide up, but longer _____

Screw

- _____ wrapped around a _____

Wedge

- Two _____

Pulley

- Grooved _____
- Changed _____ of force
- In combination, can _____ force

What is the mechanical advantage of the inclined plane?

What is the weight of the cart assuming no friction?

Forces and Torques in Muscles and Joints

- Muscles only _____, so they come in _____
- Muscles are attached to _____ close to the joints using _____
- This makes the muscles supply _____ force than is _____
- Input force _____ output force
- MA _____

Homework

1. Why are the forces exerted on the outside world by the limbs of our bodies usually much smaller than the forces exerted by muscles inside the body?

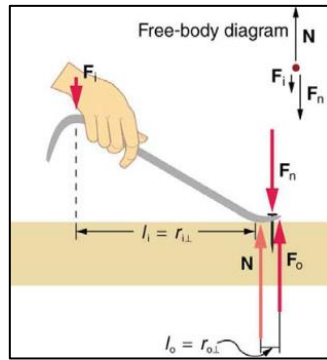

Figure 1

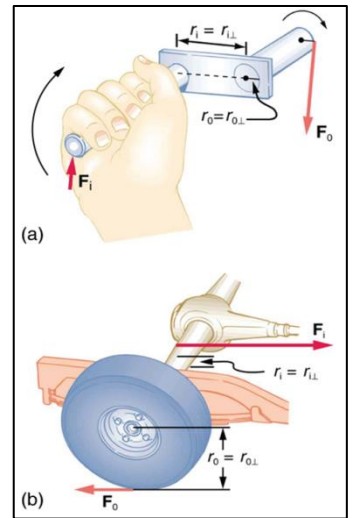

Figure 2

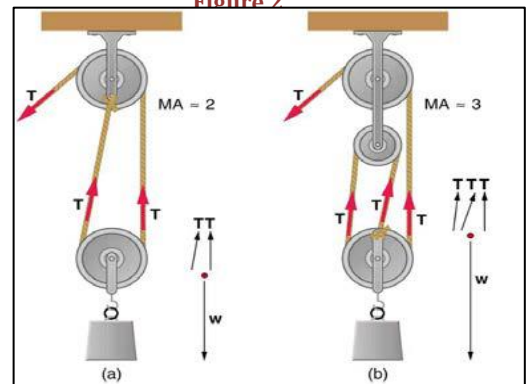

Figure 3

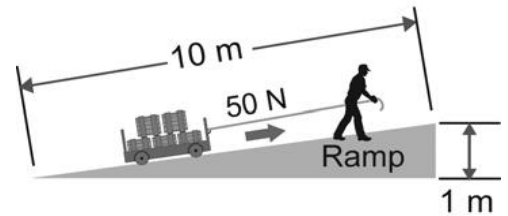

Figure 4

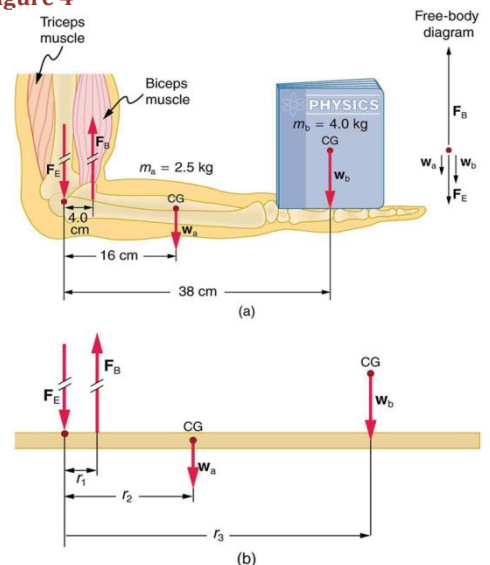

Figure 5

To be used with OpenStax College Physics

2. Explain why the forces in our joints are several times larger than the forces we exert on the outside world with our limbs. Can these forces be even greater than muscle forces?

3. Certain types of dinosaurs were bipedal (walked on two legs). What is a good reason that these creatures invariably had long tails if they had long necks?

4. If the maximum force the biceps muscle can exert is 1000 N, can we pick up an object that weighs 1000 N? Explain your answer.

5. Explain one of the reasons why pregnant women often suffer from back strain late in their pregnancy.

6. What is the mechanical advantage of a nail puller—similar to the one shown in Figure 1—where you exert a force 45 cm from the pivot and the nail is 1.8 cm on the other side? What minimum force must you exert to apply a force of 1250 N to the nail? (OpenStax 9.19) **25.0, 50.0 N**

7. Suppose you needed to raise a 250-kg mower a distance of 6.0 cm above the ground to change a tire. If you had a 2.0-m long lever, where would you place the fulcrum if your force was limited to 300 N? (OpenStax 9.20) **1.78 m**

8. (a) What is the mechanical advantage of a wheelbarrow, such as the one in Figure 6, if the center of gravity of the wheelbarrow and its load has a perpendicular lever arm of 5.50 cm, while the hands have a perpendicular lever arm of 1.02 m? (b) What upward force should you exert to support the wheelbarrow and its load if their combined mass is 55.0 kg? (c) What force does the wheel exert on the ground? (OpenStax 9.21) **18.5, 29.1 N, 510 N**

9. A typical car has an axle with 1.10 cm radius driving a tire with a radius of 27.5 cm. What is its mechanical advantage assuming the very simplified model in Figure 2b? (OpenStax 9.22) **0.0400**

10. What force does the nail puller in Exercise 6 exert on the supporting surface? The nail puller has a mass of 2.10 kg. (OpenStax 9.23) **1.30 × 10³ N**

11. If you used an ideal pulley of the type shown in Figure 7 to support a car engine of mass 115 kg, (a) What would be the tension in the rope? (b) What force must the ceiling supply, assuming you pull straight down on the rope? Neglect the pulley system's mass. (OpenStax 9.24) **564 N**

12. A device for exercising the upper leg muscle is shown in Figure 8, together with a schematic representation of an equivalent lever system. Calculate the force exerted by the upper leg muscle to lift the mass at a constant speed. (OpenStax 9.29) **1.72 × 10³ N**

13. Even when the head is held erect, as in Figure 9, its center of mass is not directly over the principal point of support (the atlanto-occipital joint). The muscles at the back of the neck should therefore exert a force to keep the head erect. That is why your head falls forward when you fall asleep in the class. (a) Calculate the force exerted by these muscles using the information in the figure. (b) What is the force exerted by the pivot on the head? (OpenStax 9.32) **25 N down, 75 N up**

14. Unlike most of the other muscles in our bodies, the masseter muscle in the jaw, as illustrated in Figure 10, is attached relatively far from the joint, enabling large forces to be exerted by the back teeth. (a) Using the information in the figure, calculate the force exerted by the lower teeth on the bullet. (b) Calculate the force on the joint. (OpenStax 9.35) **1.2 × 10² N up, 84 N down**

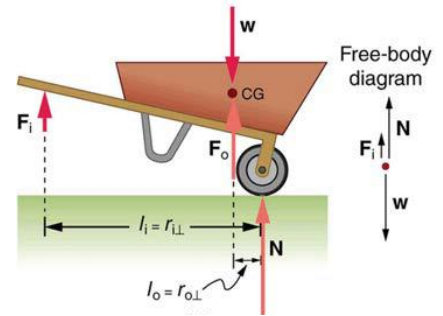

Figure 6

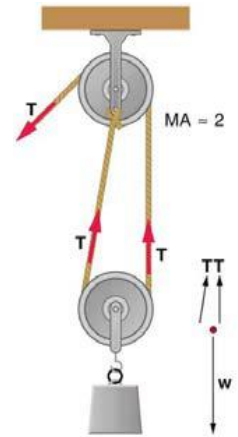

Figure 7

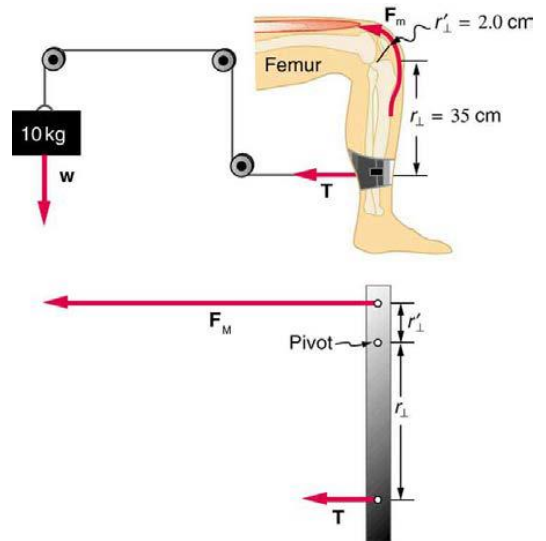

Figure 8

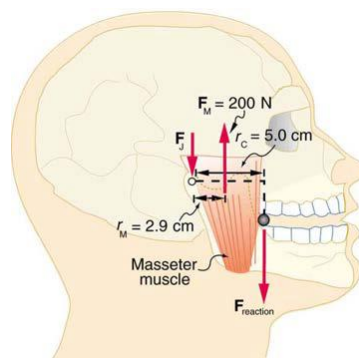

Figure 9

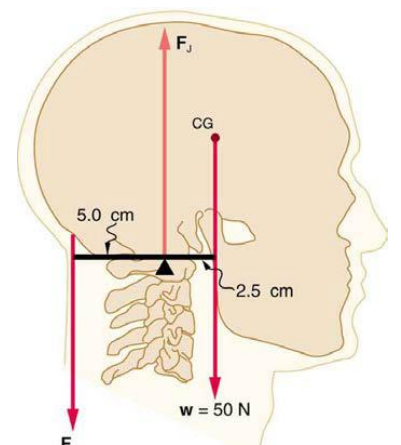

Figure 10